

VICINITY MAP
N.T.S.

OWNER & DEVELOPER
COLDSTREAM ESTATES DEVELOPMENT, LLC
7861 KEMPER ROAD
CINCINNATI, OHIO 45249

LOT DATA
MINIMUM LOT AREA: 1 ACRE
MINIMUM LOT WIDTH: 150 FEET
MINIMUM FRONT YARD: 50 FEET
MINIMUM SIDE YARD: 25 FEET
MINIMUM REAR YARD: 60 FEET

SITE ACREAGE: 35.87 AC.

PART OF PARCELS:
500-0181-0006 (-0007 CONS.)
500-0183-0001

SUBJECT PROPERTY AND ADJOINING PROPERTIES ARE ZONED A-A.

Map Unit Symbol	Map Unit Name
CnC2	Cincinnati silt loam, 8 to 15 percent slopes, eroded
CNWXXF	Chagrin-Nelse-Wheeling complex, 2 to 75 percent slopes, frequently flooded
EdD	Eden silty clay loam, 15 to 25 percent slopes
EdE	Eden silty clay loam, 25 to 40 percent slopes
EdF	Eden flaggy silty clay loam, 40 to 60 percent slopes
UAGXC	Urban land-Alic Udarents-Rossmoyne complex, 0 to 12 percent slopes
UAQXC	Urban land-Alic Udarents-Cincinnati complex, 0 to 12 percent slopes
UATXD	Urban land-Alic Udarents-Pate complex, 12 to 25 percent slopes
UcAXD	Urban land-Alic Udarents complex, clayey substratum over bedrock, 12 to 25 percent slopes
UcAXF	Urban land-Alic Udarents complex, clayey substratum over bedrock, 25 to 60 percent slopes
UfAXC	Urban land-Alic Udarents complex, fragipan substratum over till, 0 to 12 percent slopes
UsUXF	Urban land-Udorthents complex, smoothed, 0 to 50 percent slopes
W	Water

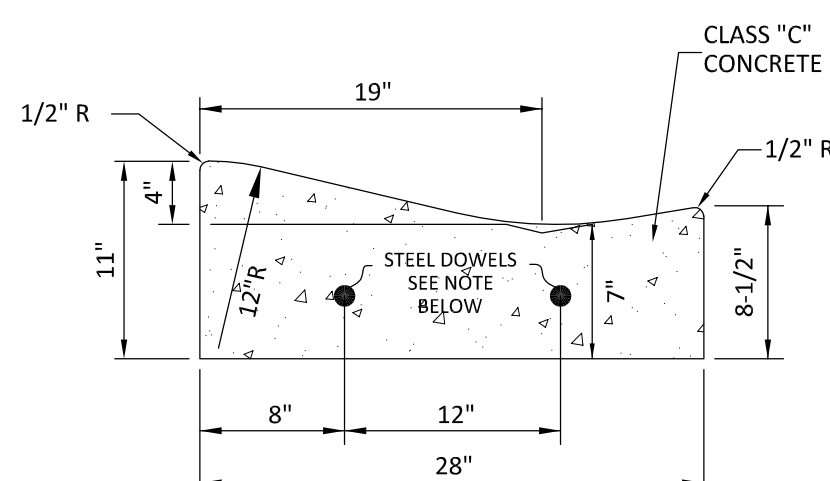

CONCRETE CURB & GUTTER SECTION

REQUIREMENTS AS SHOWN WITH EXPANSION JOINTS AT RADII AND INLETS, IMPRESSED CONTRACTION JOINTS AT 10' SPACING BETWEEN EXPANSION JOINTS.
 NOTE: ONE INCH NON-EXTRUDING EXPANSION JOINTS W/TWO DOWELS AND SLEEVES OR TWO DOWELS BAR ASSEMBLIES.

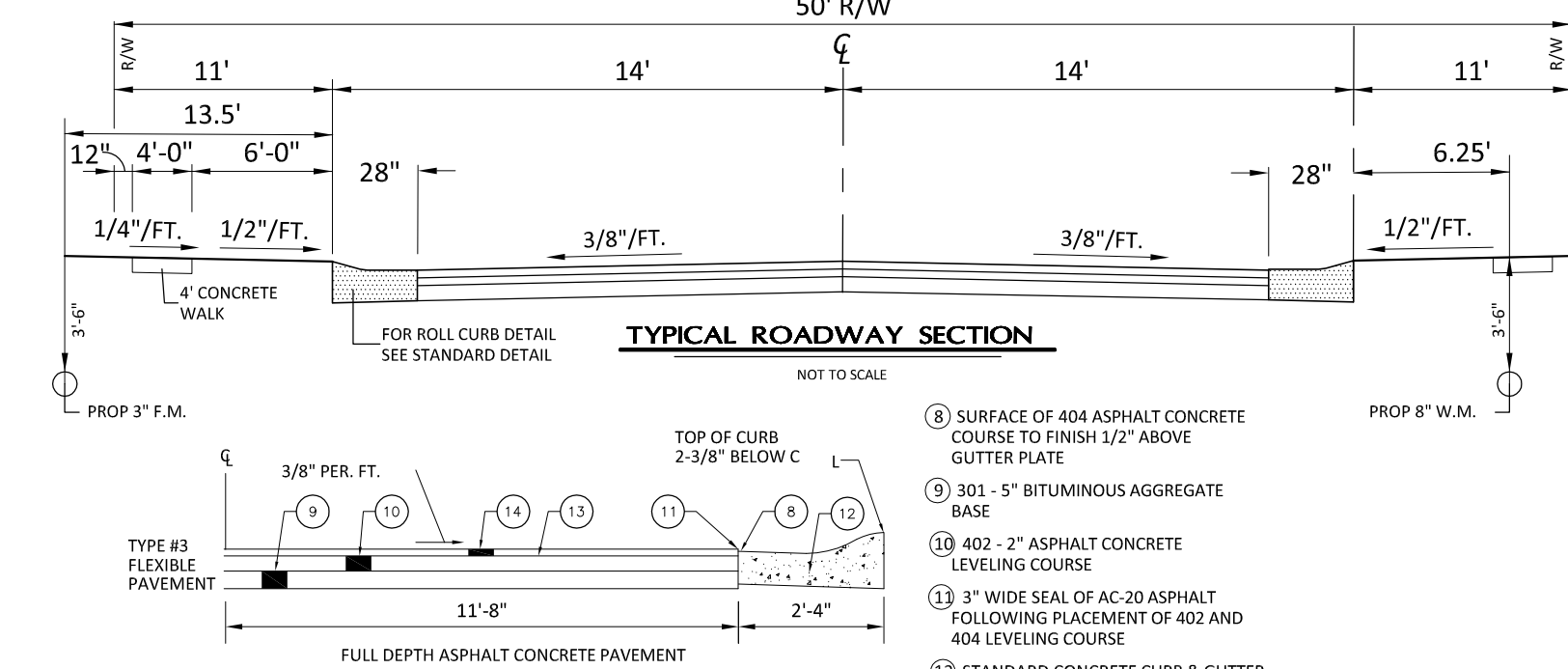

STANDARD PAVEMENT DRAWING
TYPICAL HALF SECTION OF STREETS
RESIDENTIAL SUBDIVISIONS

- ① SURFACE OF 404 ASPHALT CONCRETE COURSE TO FINISH 1/2" ABOVE GUTTER PLATE
- ② 301 - 5" BITUMINOUS AGGREGATE BASE
- ③ 402 - 2" ASPHALT CONCRETE LEVELING COURSE
- ④ 3" WIRE SEAL OF AC-20 ASPHALT FOLLOWING PLACEMENT OF 402 AND 404 LEVELING COURSE
- ⑤ STANDARD CONCRETE CURB & GUTTER (SEE DRAWING ABOVE FOR DETAILS)
- ⑥ 407 - TACK COAT TO BE APPLIED NOT LESS THAN 9 MONTHS AFTER PLACEMENT OF 402 LEVELING COURSE
- ⑦ 404 - 1" ASPHALT CONCRETE COURSE TO BE APPLIED NOT LESS THAN 9 MONTHS AFTER PLACEMENT OF 402 LEVELING COURSE

FOR ROLL CURB DETAIL SEE STANDARD DETAIL
 NOT TO SCALE

TYPE #3 FLEXIBLE PAVEMENT
 FULL DEPTH ASPHALT CONCRETE PAVEMENT

TOP OF CURB 2-3/8" BELOW C

3/8" PER. FT.

PROP 8" W.M.

11'-8"

2'-4"

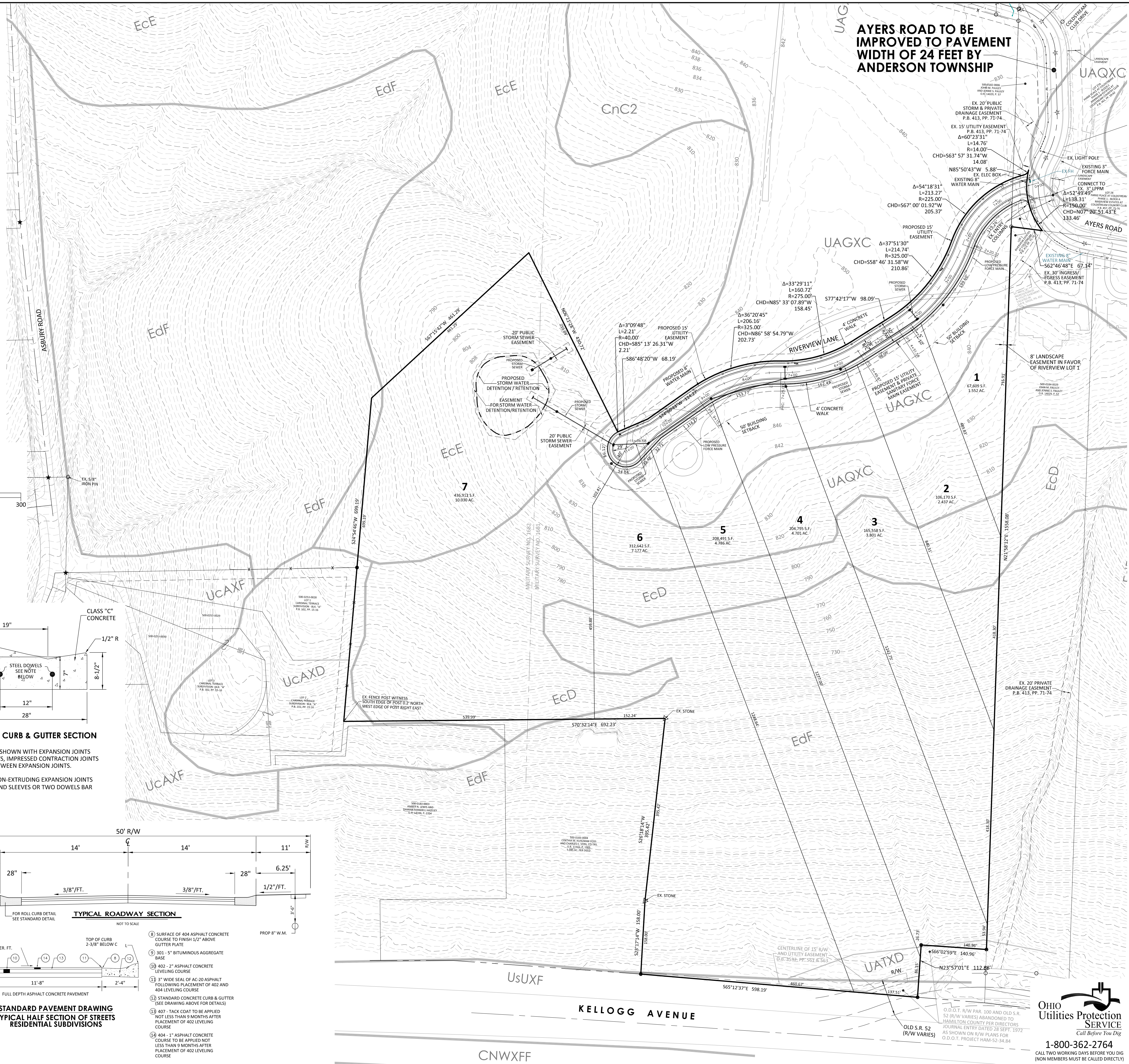
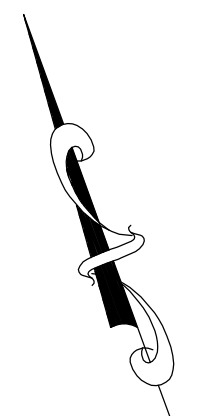
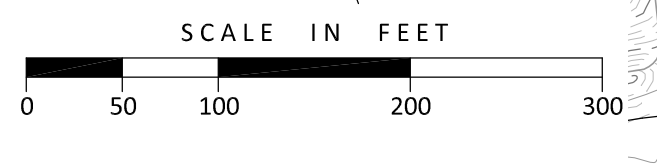

AYERS ROAD TO BE IMPROVED TO PAVEMENT WIDTH OF 24 FEET BY ANDERSON TOWNSHIP

Architecture 3700 Park 42 Drive
 Engineering Suite 1908
 Landscape Architecture Cincinnati OH 45241
 Planning Phone 513.759.0004
 Surveying www.mspsdesign.com

Project Manager RA
 Drawn By NAK
 DWG 04446024-Prelim Plat-Williams (7 Large Lots)
 X-Ref(s) 04446003-CON-Williams Property

Issue/Revision	No.	Date

© Copyright 2021, McGill Smith Punshon, Inc.

PRELIMINARY PLAN
RIVERVIEW ESTATES
AT COLDSTREAM COUNTRY CLUB
 MILITARY SURVEY #1681 & #1682
 VIRGINIA MILITARY DISTRICT
 ANDERSON TOWNSHIP
 HAMILTON COUNTY, OHIO

Sheet Title
 Preliminary Plan
 Project Number 04446.02
 Drawing Scale 1" = 100'
 Sheet Number 1/1
 File Number 04446

OHIO Utilities Protection SERVICE
 CALL TWO WORKING DAYS BEFORE YOU DIG
 1-800-362-2764
 (NON MEMBERS MUST BE CALLED DIRECTLY)